

High Current DC Feedthrough Filter 400 Amp

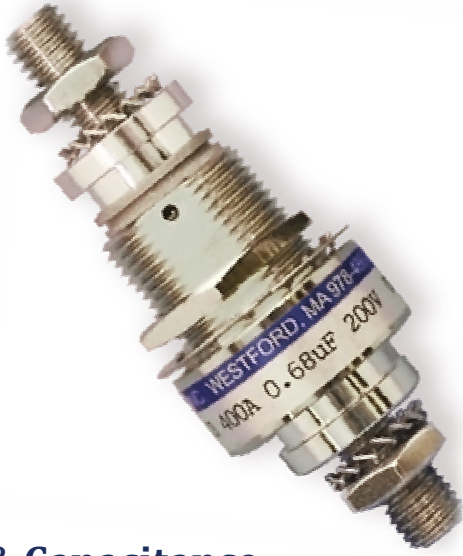

- ✓ Excellent EMI filtering
- ✓ Compact and lightweight
- ✓ "C" Type Filter
- ✓ Bolt-in style
- ✓ High Shock & Vibration
- ✓ CDR and JAN Reliability levels available

Voltage & Capacitance

400A		Capacitance μF																					
		.01	.015	.022	.033	.047	.068	.1	.15	.22	.33	.47	.68	1.0	1.5	2.2	3.3	4.7	6.8	10	15	22	
Rated Voltage	Vdc	50						+					+					+		+		+	
		100						+					+					+		+		+	
		200						+					+					+		+		+	
		500						+					+				+						
	Vac	120		+		+		+															
		250		+		+		+															

+ Standard Values

Insertion Loss

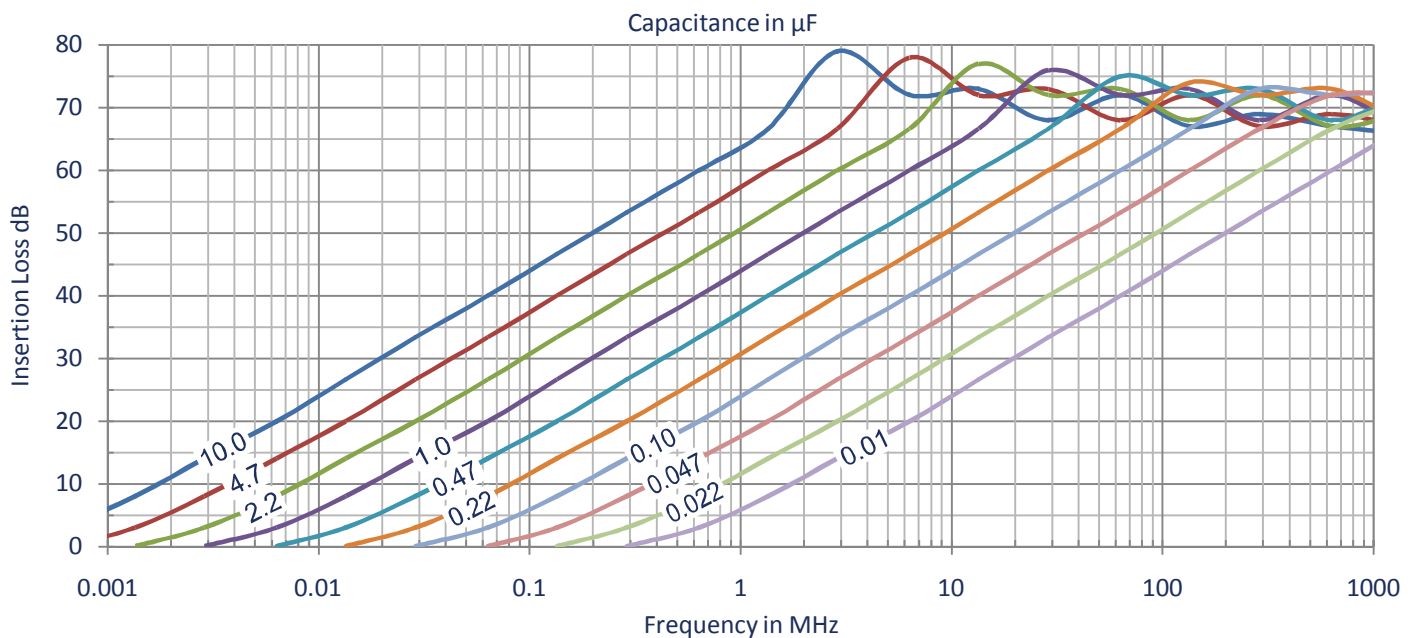

Specifications (Units to MIL-C-49467, MIL-C-55681, MIL-C-123 or customer SCD available in E-Series)

Parameter	Value	Description / Specification / Method
Current	400 Amperes	50, 55, 140, 175, 250, & 400 Amps available
Insertion Loss	See Performance Curve on page 1	Per Capacitor Value
RF Current	15A _{rms}	
Insulation Resistance	100ΩF (100MΩ Maximum) at 25°C	MIL-STD-202 Method 302
Dielectric Withstand Voltage	250% Rated Voltage (50mA 5s)	MIL-STD-202 Method 301
Dissipation Factor	3% Maximum	MIL-STD-202 Method 306
Voltage Drop	19mV	Wire to Wire
Operating Temp	-55°C to +125°C	40A@125°C to 400A@105°C
Temperature Rise	22.4°C Typical at 400A	
Heat Rise Constant	2.36 to 4.0	C ₁ in formula $\Delta T = C_1 \times W^{0.85}$
Storage Temperature	-55°C to +105°C	
Fungus	Non-Nutrient	MIL-HDBK-454A
Corrosion (metal finish)	5% NaCl / 35°C / 48 hrs	MIL-STD-202 Method 101D / Cond B
Humidity	98%RH 25°C-65°C	MIL-STD-202 Method 106E
Shock	30g – 11ms	MIL-STD-202 Method 213B / Cond A
Terminal Strength	Pull: 200lbs (91kg) Torque: 200”lbs (22Nm)	MIL-STD-202 Method 211A / Cond A & E
Reliability(MTBF)	500,000 hrs	MIL-HDBK-217F Cond - N2 A(IF) 70°C 50%V

Mechanical Specifications

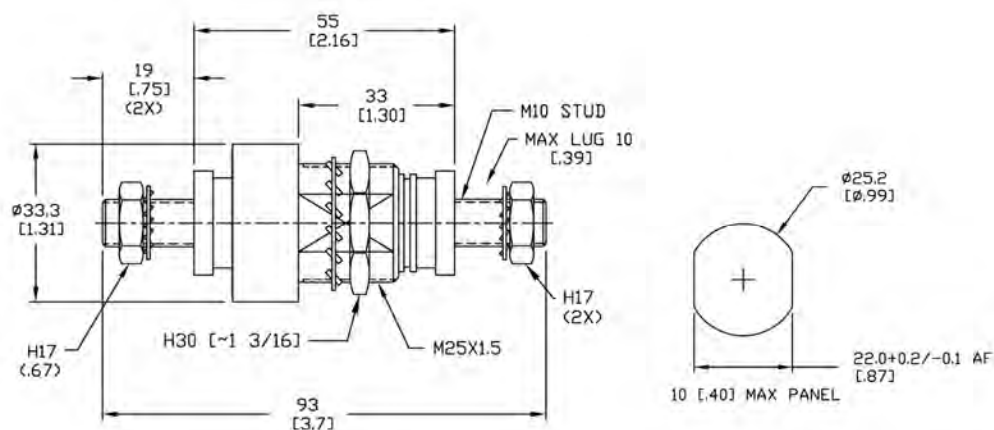

Typ Weight: 0.5Lbs (230g)

Component	Material	Finish
Metal Parts	Copper Alloy	Nickel
Insulator	FR4 or Nylon	-

Mounting

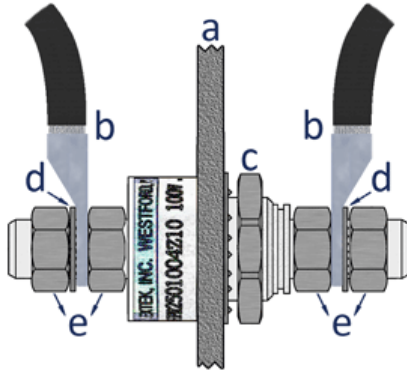

- a. Mounting Panel
- b. Lug / Wire
- c. Mounting Nut
- d. Lock Washer
- e. Electrode Lug Nut

Mounting & Electrode Torque: 200" lbs (22Nm)

Part Number

Device	Current	Capacitance	Tolerance	Voltage	Series
HPR	400	XXXX	X	XX	X

- Device** HPR High Current Feedthrough Filter
- Current** Current rating in amperes
- Capacitance** in picofarads, first two digits are significant, last two digits are number of zeros
e.g. 2203 = 22,000pF / 4704 = .47μF
- Tolerance** Capacitor Code: Z= +80%/-20% (Standard), M= +/-20%, K= +/-10%, J=+/-5%
- Voltage** Rating Code: 05=50V, 10=100V, 20=200V, 50=500V, 1K=1000V, 1A=120Vac, 2A=240Vac
- Series** Optional series designator

Example:

HPR4001004Z10 = Feedthrough Filter / 400A / 0.10uF / +80%/-20% / 100Vdc

Safety Tips

- ✓ The filter should be mounted in a grounded shielding panel
- ✓ Tighten the electrode nuts to the torque specified with the two wrench method
- ✓ Cover exposed electrode nuts
- ✓ Observe temperature, current, & voltage limits